

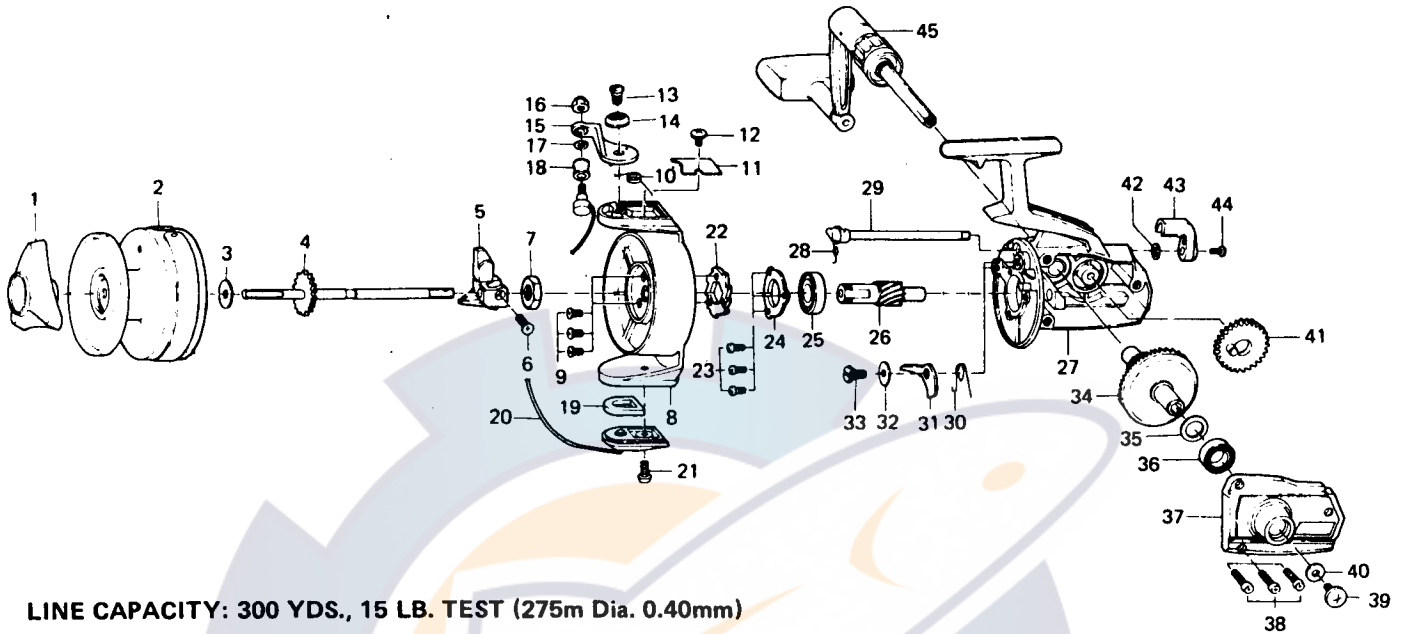

SPINNING REEL **4000c**



LINE CAPACITY: 300 YDS., 15 LB. TEST (275m Dia. 0.40mm)

Key No.	Parts No.	Parts Name	Key No.	Parts No.	Parts Name
1	60008233	Drag knob	24	66347001	Ball bearing ret. washer
2	67309101	Spool assembly	25	66331001	Ball bearing
3	63712732	Spool washer	26	64016701	Pinion
4	67102202	Main shaft	27	67001612	Body
5	64807801	Oscillating slider	28	61423511	Anti-reverse cam spring
6	63518901	Oscillating slider screw	29	67107901	Anti-reverse cam
7	63408301	Rotor nut	30	61423421	Anti-reverse claw spring
8	62012211	Rotor	31	61109701	Anti-reverse claw
9	63520901	Ratchet screw	32	63732701	Anti-reverse claw washer
10	61435501	Bail spring	33	63624201	Anti-reverse claw screw
11	66330701	Bail spring cover	34	64123501	Drive gear
12	63501931	Bail spring cover screw	35	63712820	Drive gear washer
13	63631901	Arm lever screw	36	66317611	Ball bearing
14	61303201	Bail holder cap	37	67051611	Body cover
15	62308111	Arm lever	38	63515901	Body cover screw
16	63408501	Bail nut	39	63513631	Handle screw
17	63734501	Bail washer	40	63719521	Handle washer
18	62502801	Line roller	41	64123601	Oscillating gear
19	62103501	Balancer	42	63732700	Anti-reverse lever washer
20	67251211	Bail	43	65408321	Anti-reverse lever
21	63516401	Bail holder screw	44	63522501	Anti-reverse lever screw
22	62804101	Ratchet	45	67452011	Handle
23	63516601	Ball bearing ret. washer screw			